

## THE REQUIRED GUIDANCE QUALITY: PRECISION

**Spieth guide gibs – flat guides with adjustable play.**

Wherever precision guides are configured without the occurrence of high forces in the fields of precision construction and mechanical engineering, guide gibs designed by Spieth are there to lend a guiding hand: They outperform the taper and pressure gibs used elsewhere.

That's because the flat linear guiding elements by Spieth combined the benefits of slideways, e.g. high damping, with minimal guide play that can be optimally adjusted during assembly.

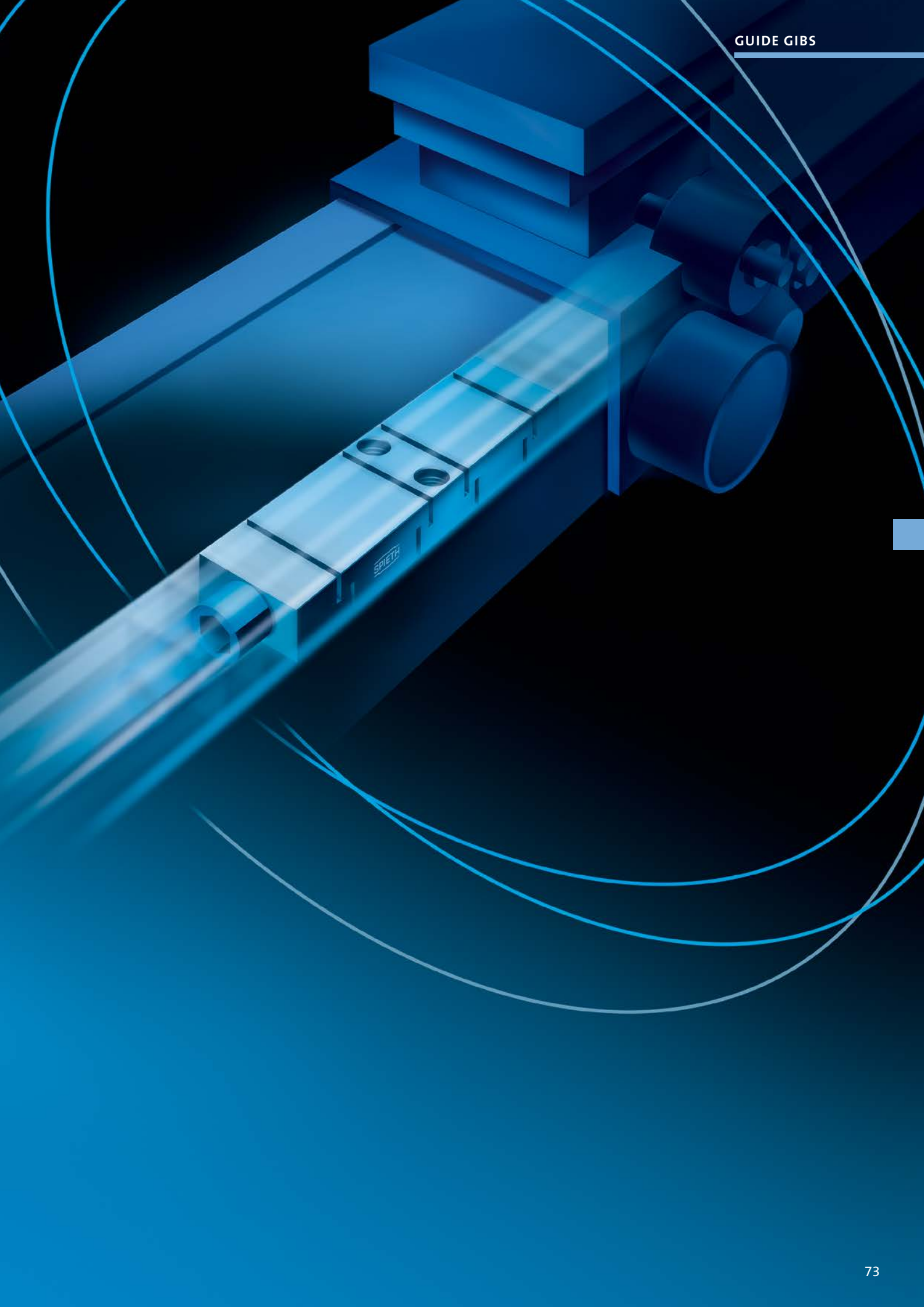

## FUNCTIONAL PRINCIPLE

---

The principle is illustrated in a simplified diagram with enlarged play.

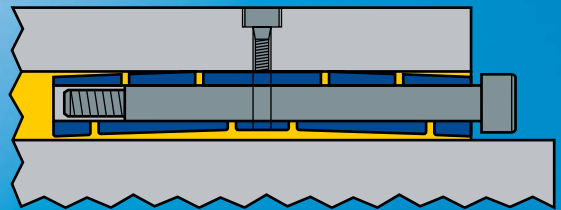

The guide gib is fastened to the machine body with the screws. In this phase, the "flying" ends of the guide gib are still not flush with the machine body.

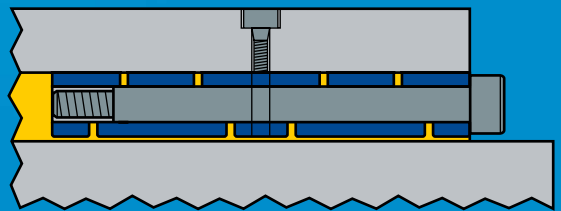

The first pre-tensioning phase causes the ends of the guide gib to press flat against the machine body.

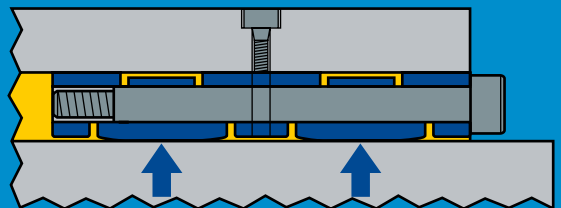

After further axial tensioning, the movement play between the guide block and the slide-way is ideally adjusted.

## SPIETH GUIDE GIBS FLW

At Spieth, you'll find the perfect guide gibs for your application. And you can rely on the expert advice of our specialists. The enhanced characteristics of the FLW series open up new possibilities for challenging linear guides.

FLW flat guides are ready-to-install machine elements that allow you to realise minimal guide play on your machines without the use of significant manual force. The process of designing and machining the contact surfaces on the surrounding components is straightforward, i.e. they are geometrically rectangular and parallel. Play is adjusted using a simple clamping screw, which is fitted on end face where it is easily accessible. This ensures that guide play can be corrected at any time if necessary.

### BENEFITS

- Low-cost precision that's ready to install.
- High degree of damping.
- Minimum stick-slip effect.
- Cost-effective installation conditions.
- Guide play can be ideally adjusted and re-adjusted.
- Outstanding tribological characteristics.

### FIELDS OF APPLICATION

FLW guide gibs are flat linear guiding elements for all areas of precision mechanical and construction engineering. By using guide gibs, you can avoid the expense of producing your own flat guides or taper and pressure gibs and the painstaking process of integrating them into the required guiding area. On-site assembly or modifications are straightforward and adjustments can be made using a central screw. Based on their design, these guide gibs are ideally suited for creating precision guides where the occurrence of high force must be avoided.



*FLW guide gib, unhardened steel,  
with a tungsten carbide coating*

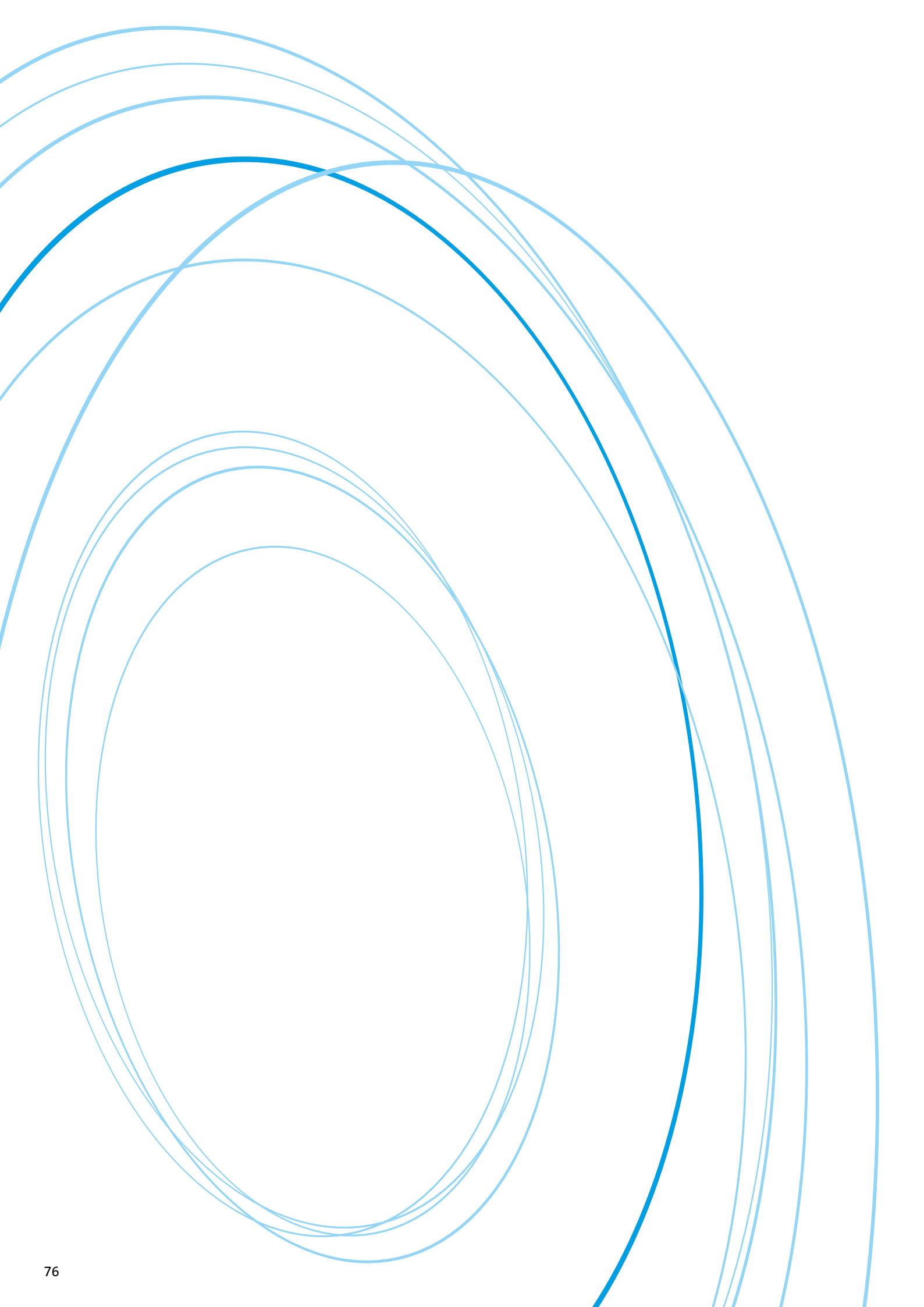

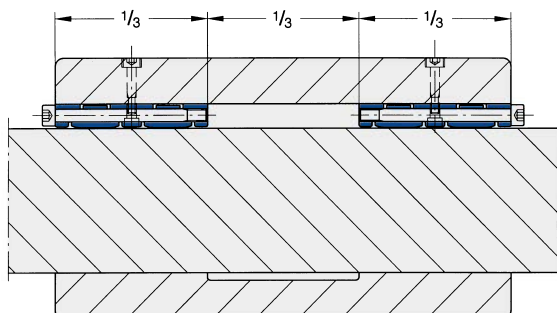
**Example 1: Guide block**

Standard arrangement of the guide gibs. In the case of a precisely executed guide, no stress occurs in the centre area of the guide block. This zone only exercises any effect when play exists (drawer effect).

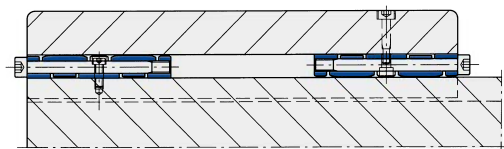
**Example 2: Guide block with restricted length**

If the length of the slideway is limited, it is possible to achieve an optimum guide basis in any guide block position by arranging one guide gib at the slideway and one guide gib at the guide block.

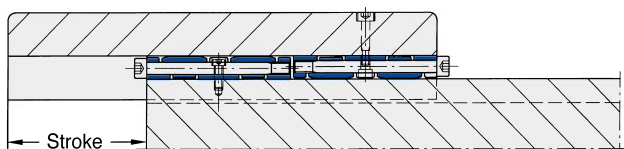
**Example 3: Narrow bed guide**

The ratio between the length and width of the guide (guide basis) should be as high as possible. To achieve this, the guide must be configured as a narrow bed guide in special cases.

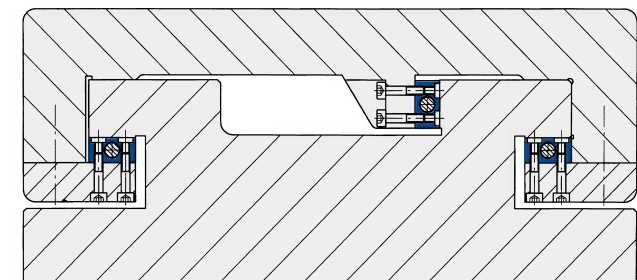



# SPIETH GUIDE GIBS SERIES FLW

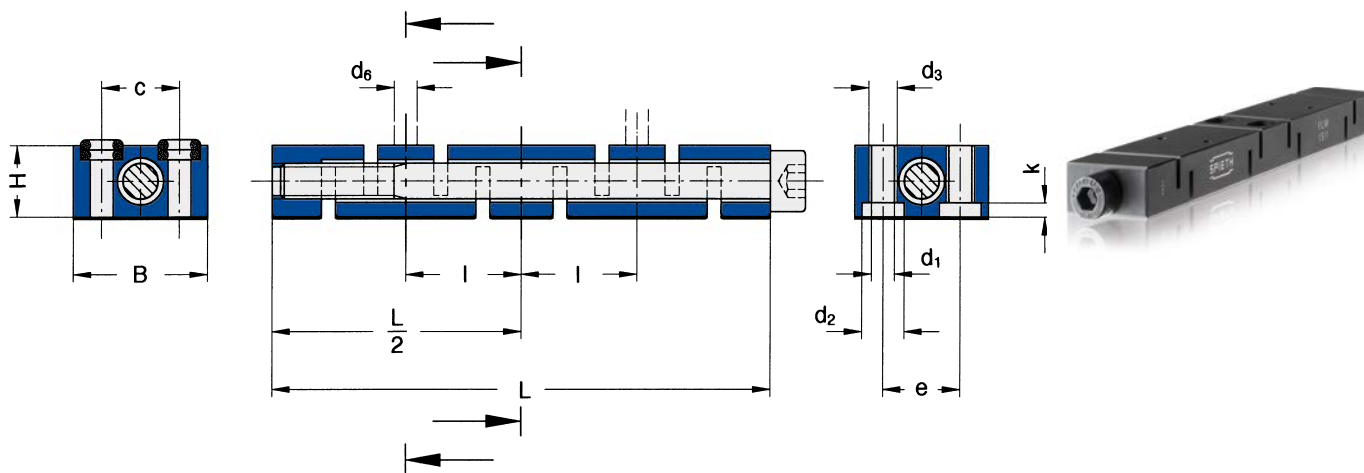

Order No.	Dimensions in mm								Clamping screws	Perm. load (Guideline values) N	Lubricant supply in mm		
	H	B	L	d <sub>1</sub>	d <sub>2</sub>	d <sub>3</sub>	e	k			ISO 4762	d <sub>6</sub>	l +/-0.1
	f6	h11											
FLW 6 <sup>1)</sup>	6	12	41	2.5	4.8	M 3	6.5	1.7	M3x40	900	-	-	-
FLW 8 <sup>1)</sup>	8	14	56	2.5	4.8	M 3	8	1.7	M4x55	1900	-	-	-
FLW 10	10	18	66	3.3	5.9	M 4	10	2.2	M5x65	2800	2.5	15	10
FLW 12	12	20	76	3.3	5.9	M 4	11	2.2	M6x75	3600	2.5	17.5	11
FLW 12/1	12	20	110	3.3	5.9	M 4	11	2.2	M6x110	7000	2.5	26.5	11
FLW 15	15	25	100	4.3	7.4	M 5	15	3	M8x100	6000	2.5	22.2	15
FLW 15/1	15	30	150	6.8	10.4	M 8	18	4.5	M8x150	18000	2.5	34	18
FLW 20	20	35	200	6.8	10.4	M 8	22	4.5	M12x200	28000	3	44	22
FLW 26	26	45	250	8.4	13.5	M10	28	6	M16x250	45000	3	54	28

<sup>1)</sup> FLW 6 and FLW 8 without lubrication boreholes.

All information is supplied without liability and subject to technical changes. Please observe the operating instructions at <https://www.spieth-maschinenelemente.de/en/download-faqs/catalogueinstructions/>

The guide gibs are made of steel (unhardened), ground parallel on all sides and coated with tungsten carbide. The integrated clamping screws are cheese-head screws to ISO 4762 (DIN 912), which are tightened with an ISO 2936 (DIN 911) screwdriver. The boreholes used to fasten the guide gibs are fitted with a thread and a recess for the screw head. This arrangement provides 2 different fixing options. The guide gibs are provided with lubricating boreholes and are characterised by a high level of wear resistance and favourable emergency running characteristics. Depending on the system, transverse grooves are provided to remove dirt.

### Sliding properties of tungsten carbide compared

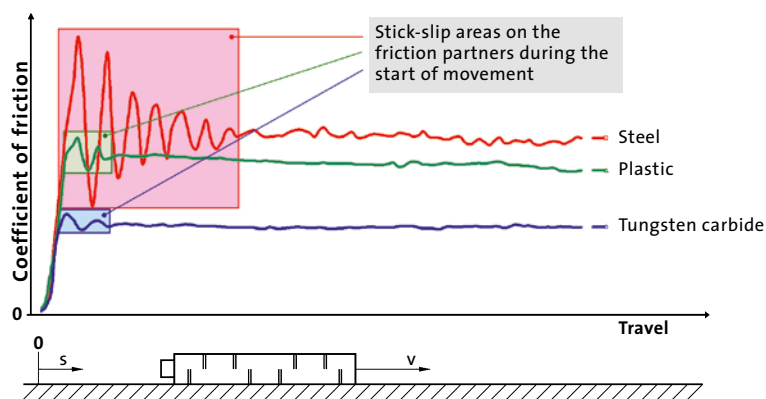

Fastening concept can be selected



Central adjustment of play



Lubrication boreholes incl. sealing rings



Coating for min. friction/wear

### CONNECTING COMPONENTS

The mounting space for the guide gibs between the slideway and the guide block must be designed to ISO tolerance H8. The recommended surface roughness for the contact surfaces  $R_z = 6.3 \mu\text{m}$ , for the sliding surfaces  $R_z = 2.5 \mu\text{m}$ . All functional surfaces must be rectangular or parallel.

The lubrication boreholes provided can be used to provide an optimum lubrication supply. Not all 4 boreholes must be used; depending on the mounting location, it is sufficient to supply the uppermost boreholes.